

**Dry All**<sup>®</sup>

Full Range of HVAC&R Line Products

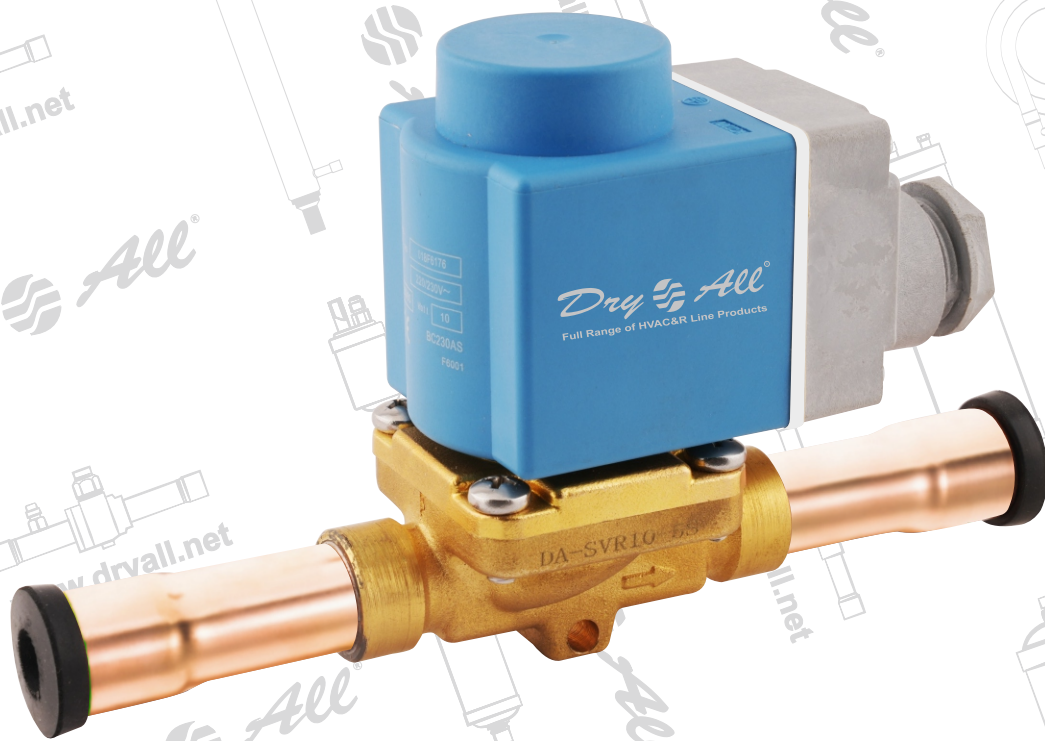

**SOLENOID VALVES  
SVR SERIES**

## INTRODUCTION

Dry All SVR Series Solenoid Valves are generally used in Refrigeration and Air Conditioning applications, for fluorinated refrigerants (HCFC, HFC and HFO).

Solenoid valves are available in a wide range of outputs, operating pressures/temperatures, connections, couplings, and with various coil types, with a variety of outputs and using the most common voltages.



- Model DA-SVR solenoid valve is a direct-operated or servo-operated valve, which is applicable to one direction flow. It is a Normally Closed (NC) valve.
- Model DA-SVR solenoid valve is used on the liquid, air suction or on the vapor line of a freezer, cold store, and Air Conditioning unit.
- The valve seat of Model DA-SVR solenoid valve is well sealed with perfect sealing performance.
- Model DA-SVR solenoid valves with various voltage solenoids are available.
- Both packed and separated Model DA-SVR solenoid valves are available and it means the valve body could be supplied separately from the solenoid.

## PRINCIPLE OF WORKING

### 1. Direct Operated Solenoid Valve

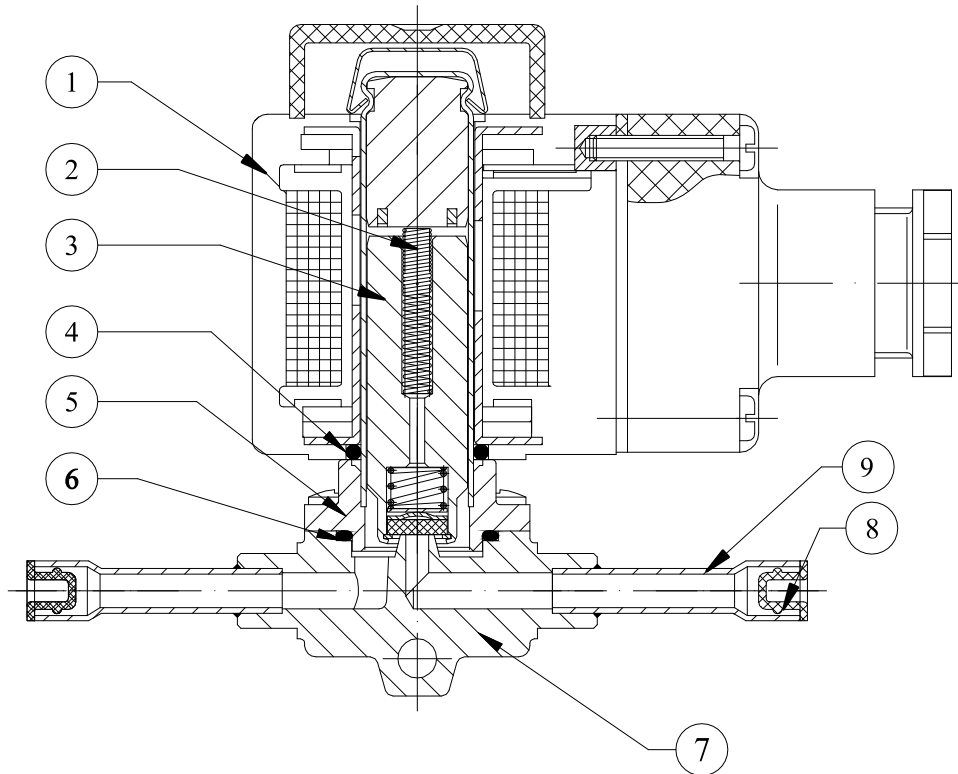

- |                           |                     |
|---------------------------|---------------------|
| 1. Solenoid Coil Body     | 2. Armature Spring  |
| 3. Iron Core Component    | 4. O-ring           |
| 5. Cover                  | 6. Screw            |
| 7. Valve Housing Assembly | 8. Solder Cover Cap |
| 9. Solder Connection      |                     |

- Model DA-SVR 3 is a direct-operated solenoid valve. When the iron core component (3) moves upward by the magnetic force of the solenoid, the solenoid valve will open directly, that is, the solenoid valve could be operated under zero pressure differential.
- The sealing valve core (modified PTFE) is directly, mounted on the iron core component
- The inlet pressure is applied onto the iron core from the upper side. Therefore, the joint action of the inlet pressure, spring force and self-gravity of the iron core component will close the valve when the solenoid is not energized.

## PRINCIPLE OF WORKING

## 2. Servo Operated Solenoid Valve

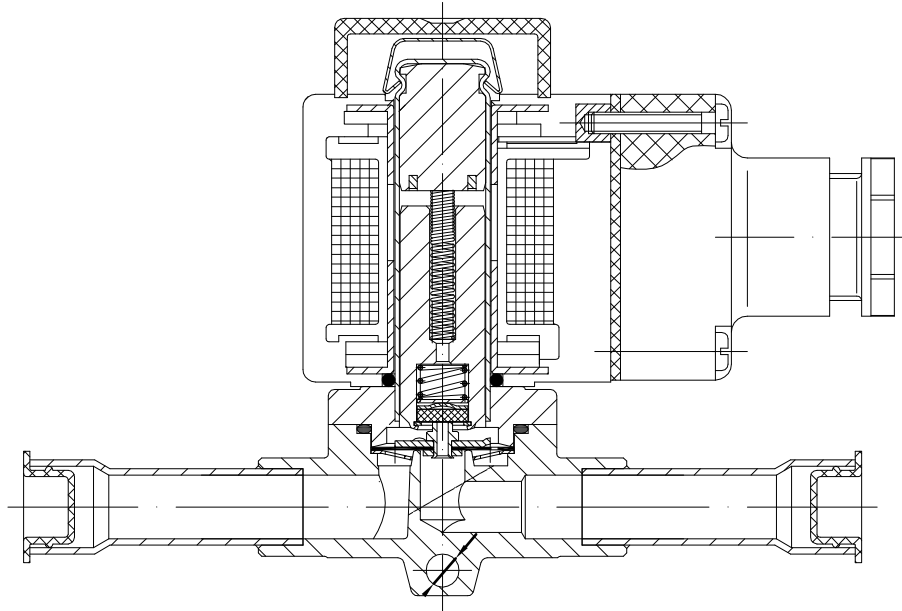

- Model SVR 6/10/15/20 are servo-operated solenoid valves with movable valve core (7). The guide valve core diaphragm (modified PTFE compound diaphragm) are mounted on the valve core.
- The main valve port and guide valve port is closed when the solenoid is not energized. The joint action of the self-gravity of the iron core component, spring force and the pressure differential between inlet and outlet will close valve.
- When the solenoid is energized, the iron core component (3) moves upward to open the guide valve on the diaphragm. The moment the pressure on the diaphragm is decreased and the space above the diaphragm is communicated with the outlet of the valve. The pressure differential between the inlet and outlet moves the diaphragm upward and open. Therefore, it needs a minimum pressure differential to open the valve and maintain the opening.
- When the power is cut off, the guide valve on the diaphragm is closed and the balance hole on the diaphragm will the pressure rise as the same as the inlet pressure. Consequently, the diaphragm will move downward to close the main valve port.

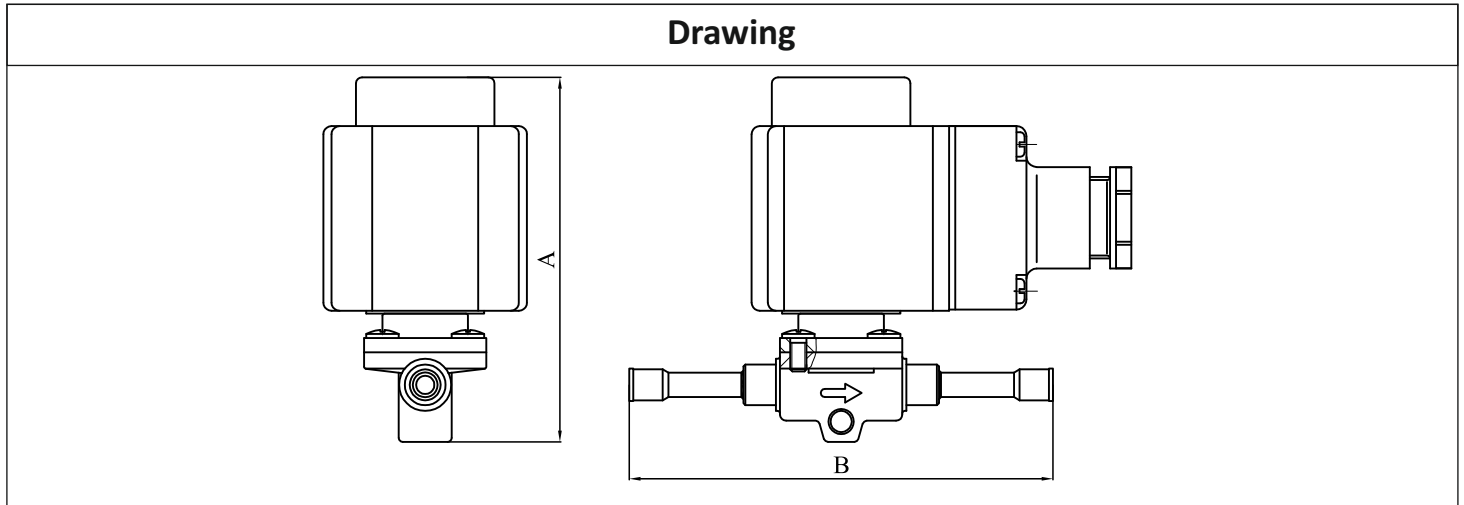

### 1. Max Working Pressure and $K_v$ Values

Sr.No	Model No	Connection Type	Dimensions (mm)		$\Delta P$ (Bar) Liquid		Max Working Pressure (Bar)	$K_v$ (m <sup>3</sup> /hr)
		Soldered	A	B	Min	Max		
1	DA-SVR3-2S	1/4"	90	102	0	31	45	0.2
2	DA-SVR3-3S	3/8"	90	118				0.3
3	DA-SVR6-3S	3/8"	90.9	124	0.05			0.8
4	DA-SVR6-4S	1/2"	91	130				0.8
5	DA-SVR10-4S	1/2"	93	138				1.9
6	DA-SVR10-5S	5/8"	93	156	0.2			1.9
7	DA-SVR15-5S	5/8"	114	168				2.6
8	DA-SVR20-7S	7/8"	126	191				5.0
9	DA-SVR25-9S	1-1/8"	133	246				10.0

- $K_v$  : The flow rate (m<sup>3</sup>/h) of water of density 1000Kg/m<sup>3</sup> passing through the solenoid valve under the pressure differential of 100 KPa.
- The Max  $\Delta P$  of the gaseous medium is about 1 bar higher than that of liquid.

**TECHNICAL DATA**

**2. Refrigeration Capacity (kW)**

Sr.No	Model No	Nominal Refrigerating Capacity kW								
		Liquid			Air Suction			Hot Vapour		
		R22\R407C	R134a	R404A\R507	R22\R407C	R134a	R404A\R507	R22\R407C	R134a	R404A\R507
1	DA-SVR3	5.4	5	3.8	-	-	-	2	2	2
2	DA-SVR6	16.1	14.8	11.2	1.8	1.3	1.6	7.4	5.9	6
3	DA-SVR10	38.2	35.3	26.7	4.3	3.1	3.9	17.5	13.9	14.3
4	DA-SVR15	52.3	48.3	36.5	5.9	4.2	5.3	24	19	19.6
5	DA-SVR20	101	92.8	70.3	11.4	8.1	10.2	46.2	36.6	37.7
6	DA-SVR25	201	186	141	22.8	16.3	20.4	92.3	73.2	75.3

**3. Technical Parameters and Features**

Technical Parameters	
Applicable Refrigerants	HCFC or HFC ( Customer specified)
Applicable Medium Temperature	-30°C to 105°C
Application Ambient Temperature of Solenoid	-40°C to 65°C
Standard Voltage of Solenoid	AC 308V/50Hz, 220V/50Hz (Customer design is available )
Allowable Voltage Fluctuation for Solenoid	+10% , 15%
Connection of Solenoid	Standard 3-wire Insert Connector

## Application of Solenoid Valve in Refrigeration and Air-Conditioning Cycle

### 1. Suction Applications

In a suction application, the solenoid valve helps complete segregation for temperature control and defrosting, or operates as a suction bypass valve on installation with two or more evaporators in a series.

### 2. Compressor Unloading

Solenoid valves can be used to “unload” compressors in many ways. The most common method is as follows:

Step

- A. A solenoid is employed to divert discharge pressure to a piston that, when activated, “blocks” the suction valve in an open position.
- B. With the valve blocked open, no compression takes place in that cylinder.
- C. This lack of compression results in a drop in capacity.

### 3. Hot Gas Bypass

The compressor capacity can be reduced by bypassing the hot discharge gas through a solenoid directly to the suction line. A De-superheating valve must be used in this type of system, to prevent the compressor from overheating and tripping its internal protector.

### 4. Hot Gas Defrost

When defrost is required, the solenoid in the hot-gas-bypass system opens. This allows discharge gas to go to the evaporator, thereby defrosting the coil

**Hologram for Genuine  
Product**

Manufactured by:



Full Range of HVAC&R Line Products

**SAFE A&T Technology Private Limited**

D-4, MIDC, Phase II, Dombivali (E),

Dist. Thane-421 201.

T : +91-(0)-251-2870680/81/82

M : +91-9619933838

Customer Care : +91 8181 994 994

E : [info@dryall.net](mailto:info@dryall.net)

W : [www.dryall.net](http://www.dryall.net)