

**Dry All**

Full Range of HVAC&R Line Products

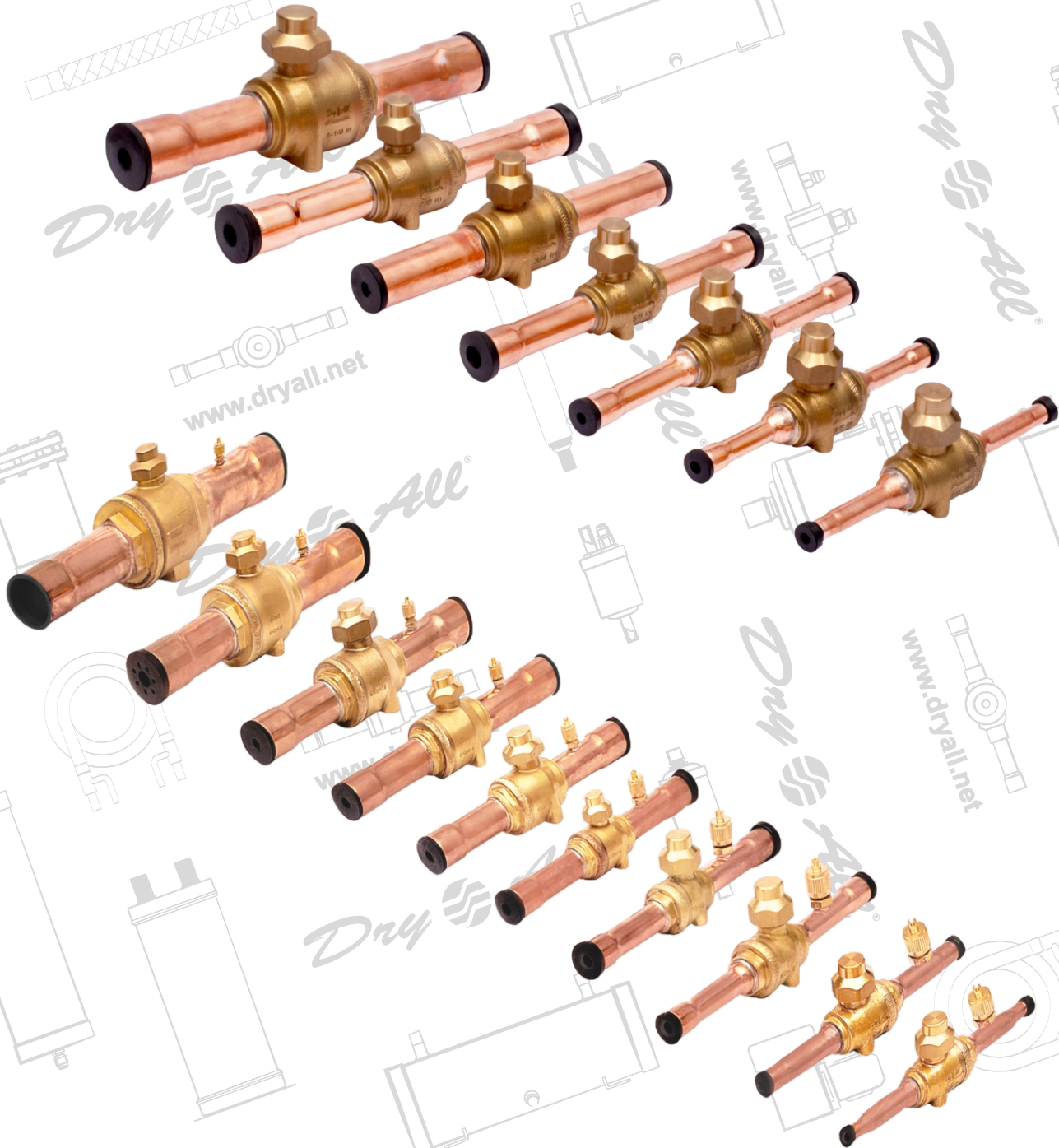

**BALL VALVES**

## Introduction

Dry All Ball valve is a two-way valve that is operated manually to open or close the flow of refrigerant. These are expertly crafted manual shut-off valves designed to facilitate bi-directional flow. It incorporates single turn on/off mechanisms to ensure that it is fully open or closed. The unique featured steel ball mechanism allows 100% opening or closure.

The construction of valve includes brazed connections and hermetically welded joints to guarantee a sturdy yet lightweight, slim-line body design. Meticulous attention to design, weld quality, and the selection of premium sealing materials empowers these ball valves to surpass even the most stringent demands, such as high working pressures while handling R410A refrigerant.

The construction of valve includes brazed connections and hermetically welded joints to guarantee a sturdy yet lightweight, slim-line body design. Meticulous attention to design, weld quality, and the selection of premium sealing materials empowers these ball valves to surpass even the most stringent demands, such as high working pressures while handling R410A refrigerant.

Dry All Ball valves serve as manually operated shut-off valves that efficiently handle bi-directional flow in refrigeration, freezing, and air conditioning systems. Their versatility allows them to be utilized in liquid, suction, and hot gas lines. Specifically, the bidirectional ball valves offer the option of being delivered with or without an external access port. To enhance safety and prevent any inadvertent cap removal or tampering during service intervals, these valves have vent hole which permits a safe discharge of the refrigerant present under the cap. This feature ensures the integrity of the valve's functionality and maintenance procedures.

Based on years of experience in manufacturing a full range of HVAC&R line products, Dry All adeptly applies its knowledge to a variety of products.

## Key Features

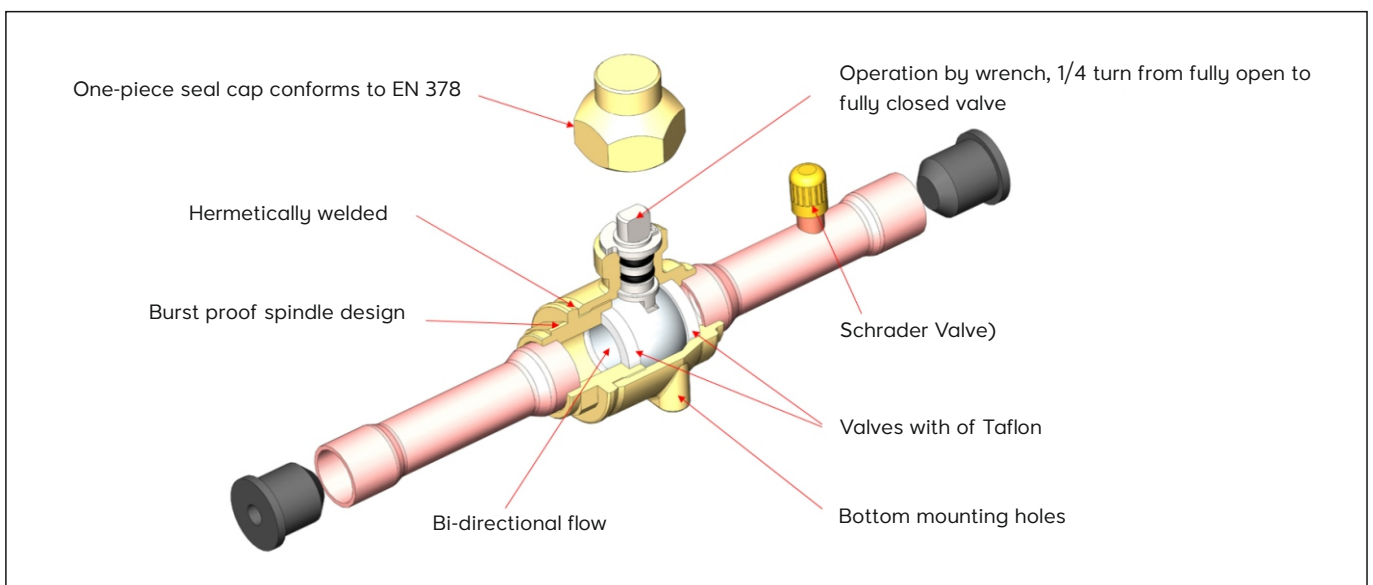

Application	Advantages
<ul style="list-style-type: none"> <li>• Dry All Ball valves are used in hot gas, liquid and suction lines in all refrigeration and air conditioning systems with fluorinated refrigerants.</li> </ul>	<ul style="list-style-type: none"> <li>• Full flow with minimum pressure drop.</li> <li>• Bi-directional flow, i.e. valve orientation is unimportant.</li> <li>• Slimline design ensures easy operational handling.</li> <li>• Burst proof spindle design prevents liquid from being trapped internally.</li> <li>• Valve seat of special Teflon to secure maximum tightness and a long lifetime.</li> <li>• The available access port saves money if service of the system is necessary.</li> </ul>

## Technical Properties

- Ball valves can be used for all fluorinated refrigerants such as CFC, HCFC, HFC, HFO & HC refrigerants and oils.
- Temperature range: -40°C to +150°C.
- Max. Working pressure (PS/MWP): 45bar (650 psig).
- Test pressure: 67.5bar (970 psig).
- Body Material: Forged brass (EN 12420, EN12165, and CW617N).
- Tube Material: Copper (EN12735-1).
- Leak rate is less than 2.8g/year.
- Approvals: UL and RoHS.

# BALL VALVES

## Image & Technical Data

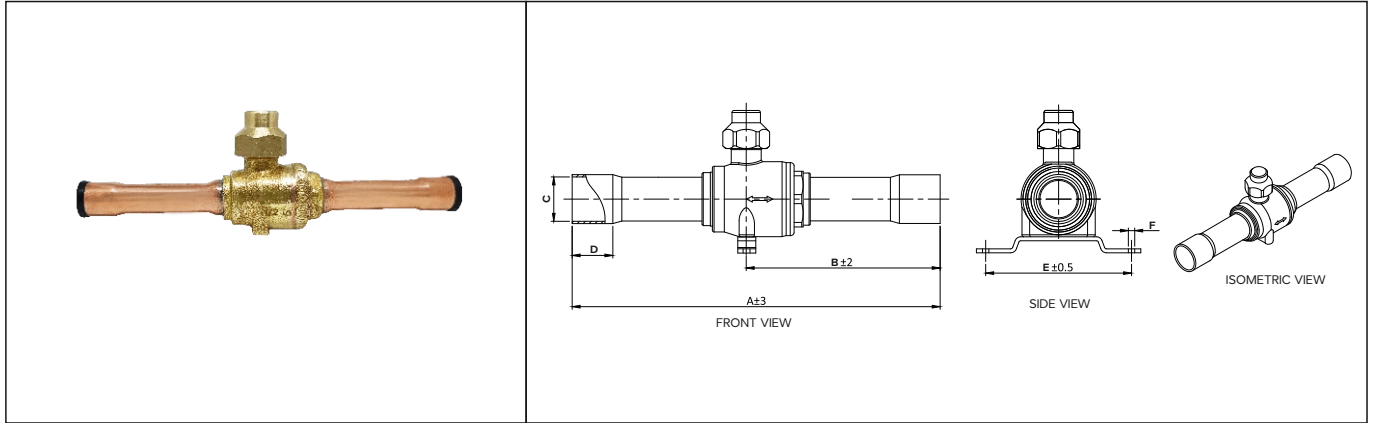

## Available Models (without Schrader Valve)

S/N	Model No	End Connection	A		B		C		D		E		F
			mm	Inch	mm	Inch	mm	Inch	mm	Inch	mm	Inch	mm
1	DABV-02S	1/4" ODF	134	5.27	73	2.87	Ø6.4	0.25	8	0.31	49.5	1.94	Ø4.5x6x2 SLOT
2	DABV-03S	3/8" ODF	134	5.27	73	2.87	Ø9.6	0.37	8	0.31	49.5	1.94	Ø4.5x6x2 SLOT
3	DABV-04S	1/2" ODF	156	6.14	84	3.30	Ø12.8	0.5	11.5	0.45	49.5	1.94	Ø4.5x6x2 SLOT
4	DABV-05S	5/8" ODF	156	6.14	84	3.30	Ø15.95	0.62	13	0.51	49.5	1.94	Ø4.5x6x2 SLOT
5	DABV-06S	3/4" ODF	166	6.53	91.3	3.59	Ø19.1	0.75	16	0.62	70	2.75	Ø4.5x6x2 SLOT
6	DABV-07S	7/8" ODF	184	7.24	100.3	3.94	Ø22.3	0.87	20	0.78	70	2.75	Ø4.5x6x2 SLOT
7	DABV-09S	1"-1/8 ODF	204	8.03	113	4.44	Ø28.7	1.12	23	0.90	69	2.71	Ø4.5x6x2 SLOT

# BALL VALVES

## Image & Technical Data

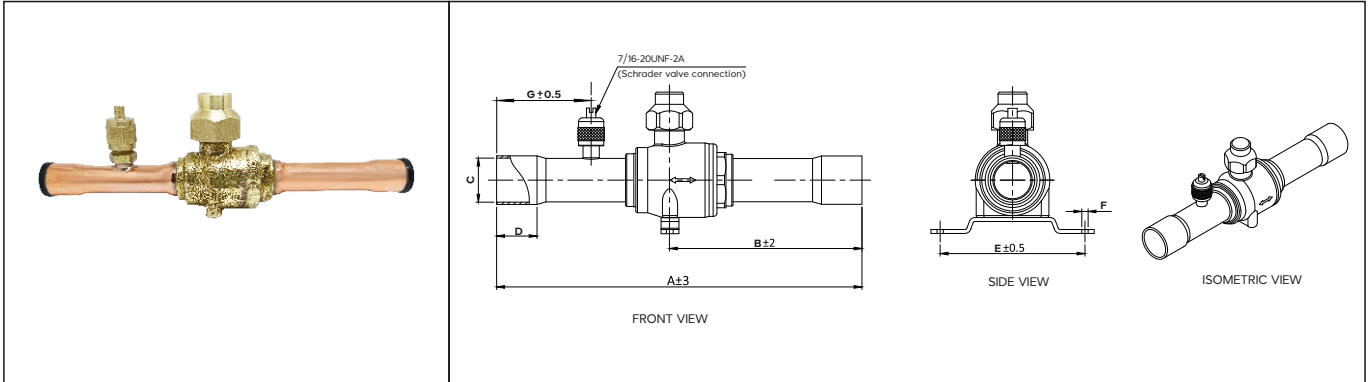

## Available Models (with Schrader Valve)

S/N	Model No	End Connection	A		B		C		D		E		F	G	
			mm	Inch	mm	Inch	mm	Inch	mm	Inch	mm	Inch		mm	Inch
1	DABVSV-02S	1/4" ODF	134	5.27	73	2.87	Ø6.4	0.25	8	0.31	49.5	1.94	Ø4.5x6x2 SLOT	26	1.02
2	DABVSV-03S	3/8" ODF	134	5.27	73	2.87	Ø9.6	0.37	8	0.31	49.5	1.94	Ø4.5x6x2 SLOT	26	1.02
3	DABVSV-04S	1/2" ODF	156	6.14	84	3.30	Ø12.8	0.5	11.5	0.45	49.5	1.94	Ø4.5x6x2 SLOT	32	1.25
4	DABVSV-05S	5/8" ODF	156	6.14	84	3.30	Ø15.95	0.62	13	0.51	49.5	1.94	Ø4.5x6x2 SLOT	34	1.33
5	DABVSV-06S	3/4" ODF	166	5.53	91.3	3.59	Ø19.1	0.75	16	0.62	70	2.75	Ø4.5x6x2 SLOT	37	1.45
6	DABVSV-07S	7/8" ODF	184	7.24	100.3	3.94	Ø22.3	0.87	20	0.78	70	2.75	Ø4.5x6x2 SLOT	42	1.65
7	DABVSV-09S	1"-1/8 ODF	204	8.03	113	4.44	Ø28.7	1.12	23	0.90	69	2.71	Ø4.5x6x2 SLOT	45	1.77
8	DABVSV-11S	1"-3/8 ODF	244	9.6	133	5.23	Ø35.1	1.38	25.8	0.01	86	3.38	Ø6.5x10x2 SLOT	55	2.16
9	DABVSV-13S	1"-5/8 ODF	258	10.15	141	5.55	Ø42.1	1.65	28	1.10	91	2.58	Ø6.5x10x2 SLOT	55	2.16
10	DABVSV-17S	2"-1/8 ODF	303	11.92	154	6.06	Ø54.1	2.12	35	1.37	106	4.17	Ø6.5x10x2 SLOT	65	2.55
11	DABVSV-21S	2"-5/8 ODF	302.5	11.90	154	6.06	Ø67.1	2.64	34	1.33	106	4.17	Ø6.5x10x2 SLOT	72	2.55

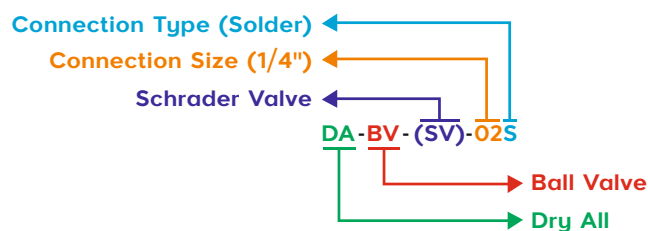

## Nomenclature

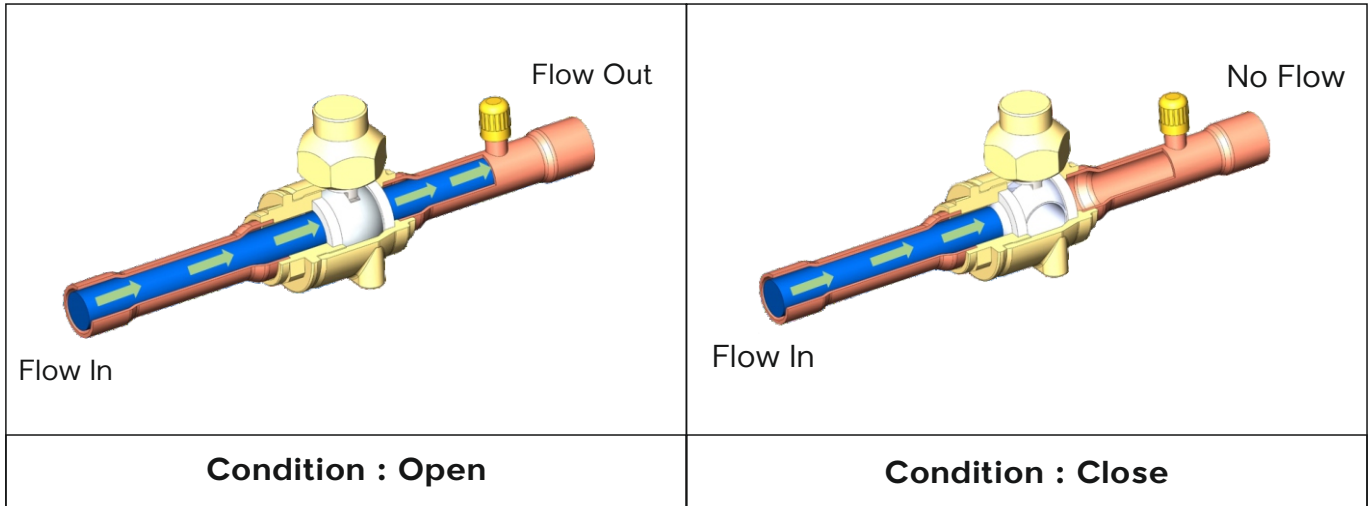

## Flow Condition

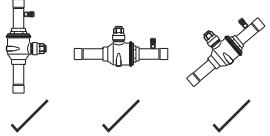

## Installation Guideline

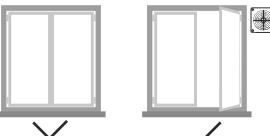
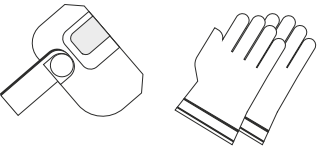
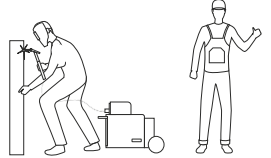
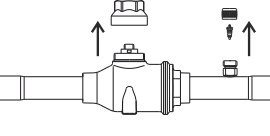
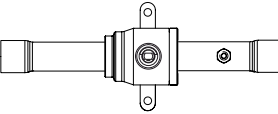
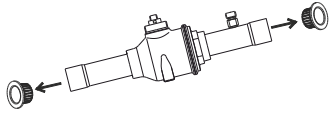
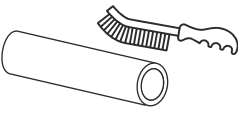
<p>Installation Positions</p>  <p>1</p>	<p>Do Installation work in normal, clean and safe atmospheric conditions. Please do not do any work in hazardous and unsafe conditions.</p>  <p>2</p>	<p>When working makes sure that the area has enough ventilation or working exhaust.</p>  <p>3</p>
<p>Use face shield or green goggles as protection for eyes. Use heat resistance gloves.</p>  <p>4</p>	<p>Wear impervious coverall clothing with breathable fabrics.</p>  <p>5</p>	<p>Remove the brass dead cap of operating spindle. also remove the cap and inner parts of Schrader Valve, if present</p>  <p>6</p>
<p>Turn the ball valve stem to open position. The pin must be positioned as shown.</p>  <p>7</p>	<p>Remove the plastic cap ends just when you are ready to braze.</p>  <p>8</p>	<p>Clean the mating parts with cleaning pad or special wire brush</p>  <p>9</p> <p>Remove all oil and grease</p> <p>Clean Outside of copper tubing</p>

## Installation Guideline Continued

Apply flux to the male connection after cleaning operation

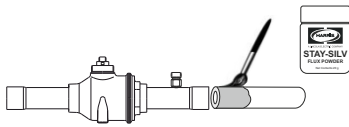

10

During brazing bleed an insert gas (dry Nitrogen or Co2)

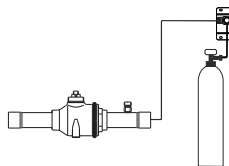

11

Wrap a wet cloth over ball valve. It must cover the existing brazed tubes on the body and spindle.

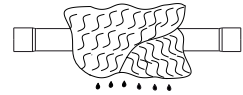

12

Preferably use oxygen-acetylene brazing equipment and a torch capable to increase temperature to the required value as soon as possible.

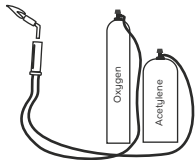

13

Use copper or high silver brazing Rod as required.

Brazing Rod

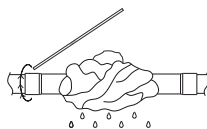

14

Ball valve Connection	Mating Part	Recommended Harries Make Brazing Alloy or Equivalent.
Copper	Copper	Most common used is Harris-O. For higher Vibration joints you may use Harries - Stay- Silve 2 / Stay-Sliv 15 / Dynaflo.
Copper	Steel	Stay-Silv 25

**15 Use Brazing Flux as required**

Flame direction should be opposite to the valve body. Do not touch the flame of the torch directly to the copper tube. Heat the tube by turning the torch around. Do not focus on one point.

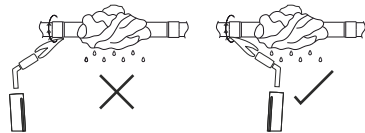

16

After brazing one side, allow it cool. Pour cold water on to the cloth to cool it further. Then apply the above listed steps again for the other side.

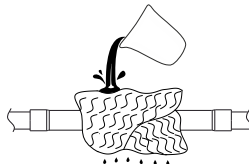

17

Do not forget to attach the brass caps and inner parts of Schrader Valve back to their places. check the Schrader Valve and connections for leaks.

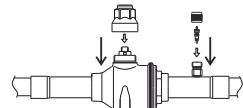

18

Tighten the cap for sealing, with the torque written on it. Please check if the gasket is properly placed in the cap.

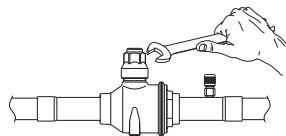

19



**Quality in everything we do**

Dry All Ball valves are integral to comprehensive line of refrigeration components, encompassing a wide array of high-tech products. Each component undergoes rigorous testing, adhering to the most stringent standards to ensure top-notch quality.

If the specific component you seek is not listed in this brochure or if you have unique requirements, rest assured that Dryall's partner wholesalers and our local team are here to assist you. They are dedicated to providing guidance and support, going above and beyond to meet your individual needs.

**Related products**

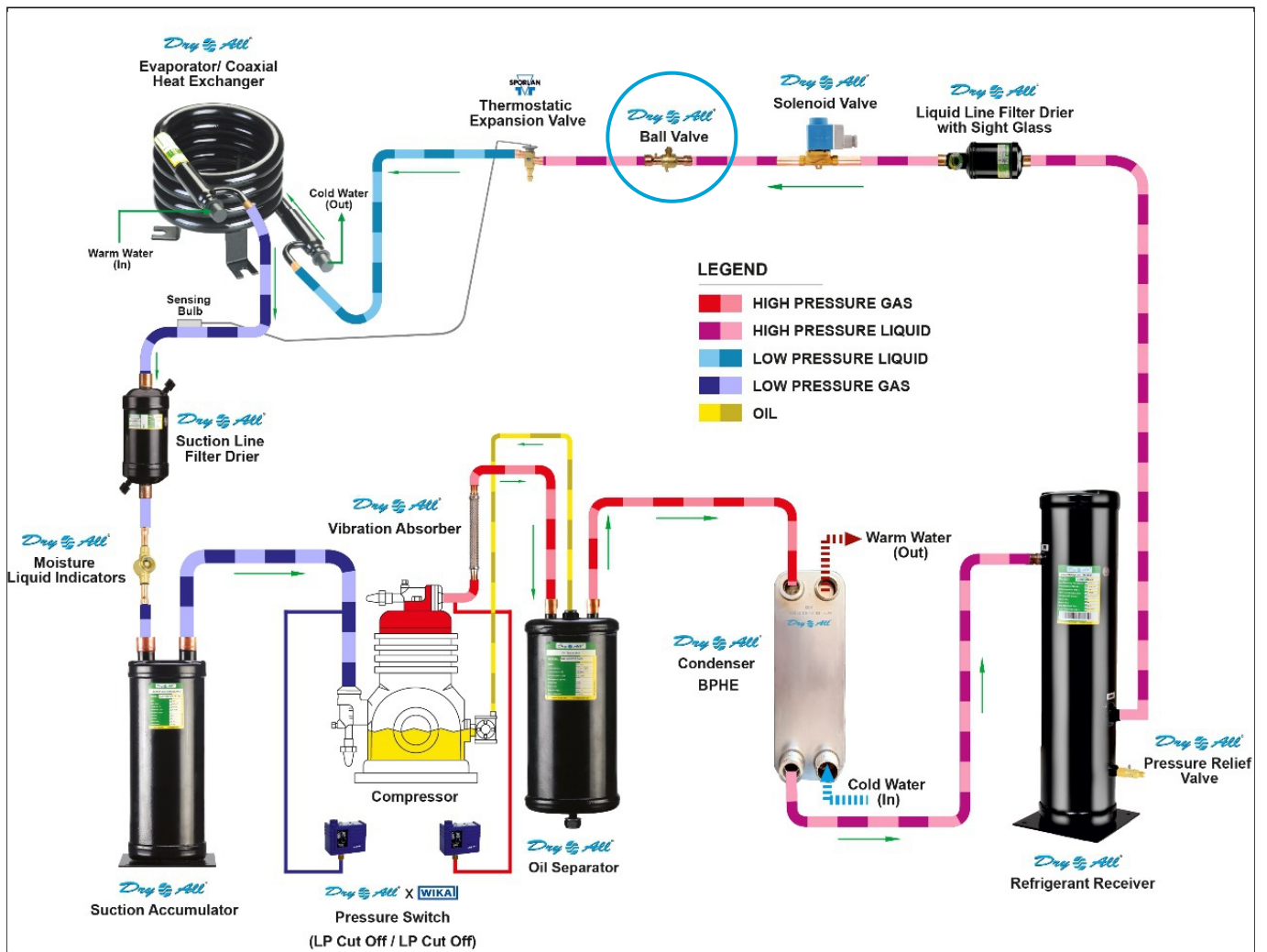



Marketed by:



Full Range of HVAC&R Line Products

**SAFE A&T Technology Private Limited**

D-4, MIDC, Phase II, Dombivali (E),

Dist. Thane-421 201.

T : +91-(0)-251-2870680/81/82

Customer Care : +91 8181 994 994

E : [info@dryall.net](mailto:info@dryall.net)

W : [www.dryall.net](http://www.dryall.net)

REV23-06-03-00