

Liquid Receiver - Installation Guideline

Installation / Location / Positioning of Receiver in HVAC&R System

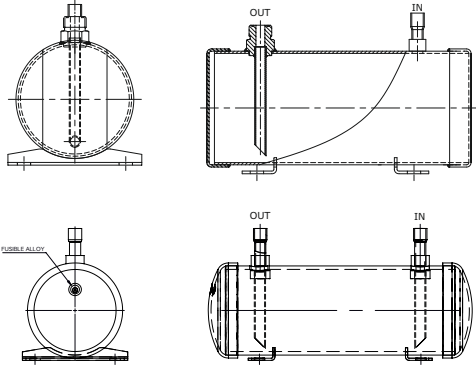

Horizontally Installed Receivers

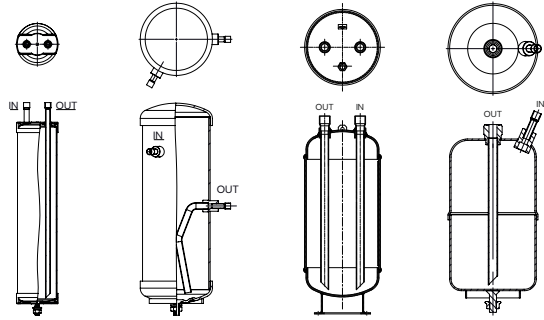

Vertically Installed Receivers



1

- To prevent moisture from entering the receiver while in transit and storage, the same is charge with positive nitrogen pressure. Hence open Cap/rubber plug when needs to install.
- Install receiver in Liquid line.
- Make sure that the same is installed as close to the condenser outlet as possible.
- Choose receiver model according to Dry All's capacity rating only.
- Ensure that incoming liquid line tubing is connected to the connection marked "IN".
- For Vertical receivers, rotate the receiver on its mounting as required for required connection orientation.
- The location of the receiver should be such that it will not heat the refrigerant inside it. (e.g. direct sunlight coming on the receiver may cause heating).

Do's & Don't

Installation should be done in normal, clean and safe atmospheric conditions. Please don't do any work in hazardous and unsafe conditions.

Use face shield or green goggles as protection for eyes. Use heat resistance gloves. Use protective coveralls made of breathable materials.



2

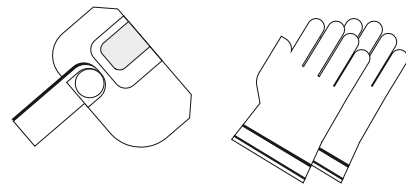

3

When working make sure that the area has enough ventilation or working exhaust

Wear impervious coverall clothing with breathable fabrics.

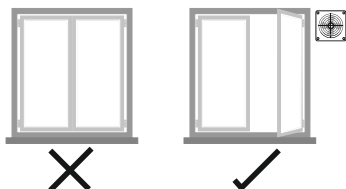

4

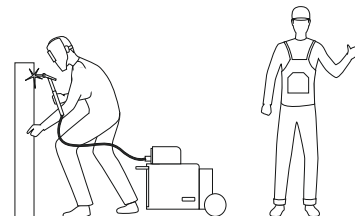

5

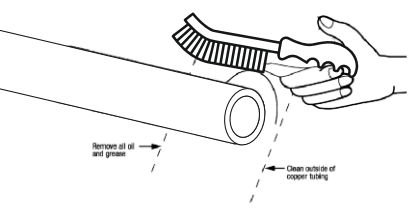
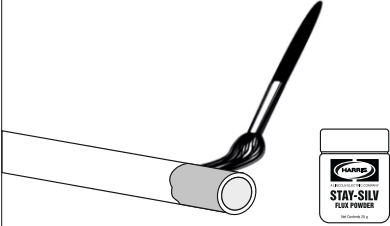
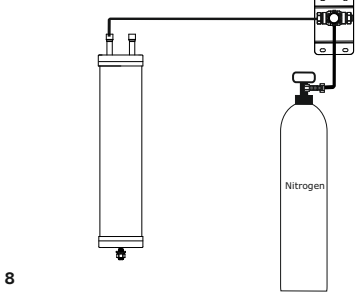
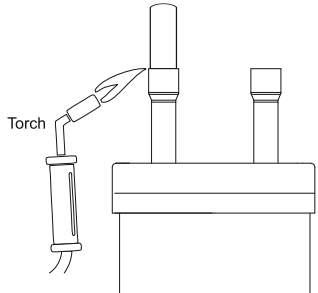
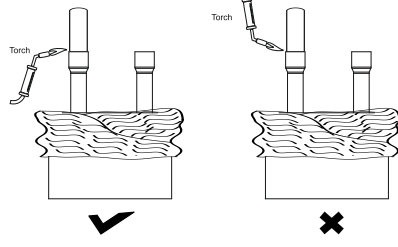
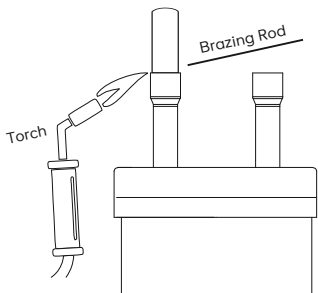

Brazing Technique:

<p>Clean the mating parts with cleaning pad or special wire brush</p>	<p>Apply flux to the male connection after cleaning operation</p>	<p>During brazing bleed an inert gas (Dry Nitrogen or CO₂)</p>
		
<p>6</p>	<p>7</p>	<p>8</p>
<p>Use a torch tip which is large enough to provide uniform heating on the mating parts.</p>	<p>Place cold wet rag on receiver body and direct the flame of torch away from end of the shell so as to avoid damaging the shell and paint due to excessive heating</p>	<p>Use copper or high silver brazing rod as required. After brazing the joint, wipe the solder joint with a rag and allow it to cool. Clean to remove excess flow (to improve the appearance) of flux if any.</p>
		
<p>9</p>	<p>10</p>	<p>11</p>

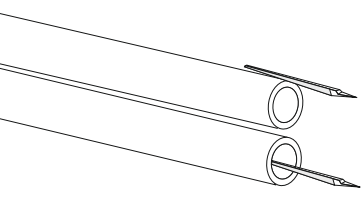
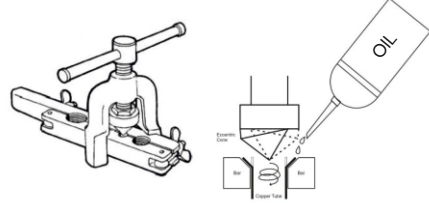
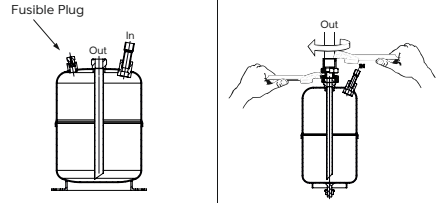
Threaded Joint Technique (SAE/O Ring/MIO/ORFS)

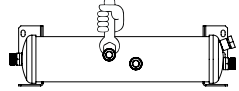
<p>Ream to remove all burrs and clean all residue from the tubing</p>	<p>A drop of refrigeration oil on the flaring tool will help to get a smooth flare</p>	<p>To prevent twisting of the refrigerant line, use backup wrench on flat supplied on Rotolock connection of receiver. Fusible Plug: Avoid using wrench on it</p>
		
<p>1</p>	<p>2</p>	<p>3</p>

	<p>Tightening Torque of Flared Joints (SAE)</p>	<p>Tightening Torque of Rotolock Joints (ORFS)</p>																																				
<p style="text-align: center;">Tightening Torque for Sight Glass</p>	<table border="1" style="width: 100%; border-collapse: collapse;"> <thead> <tr> <th>Nominal diameter</th> <th>Outer diameter (mm)</th> <th>Tightening torque N.m (kgf.cm)</th> </tr> </thead> <tbody> <tr> <td>1/4"</td> <td>6.35</td> <td>14 to 18 (140 to 180)</td> </tr> <tr> <td>3/8"</td> <td>9.52</td> <td>33 to 42 (330 to 420)</td> </tr> <tr> <td>1/2"</td> <td>12.70</td> <td>50 to 62 (500 to 620)</td> </tr> <tr> <td>5/8"</td> <td>15.88</td> <td>63 to 77 (630 to 770)</td> </tr> <tr> <td>3/4"</td> <td>19.06</td> <td>90 to 110 (900 to 1100)</td> </tr> </tbody> </table>	Nominal diameter	Outer diameter (mm)	Tightening torque N.m (kgf.cm)	1/4"	6.35	14 to 18 (140 to 180)	3/8"	9.52	33 to 42 (330 to 420)	1/2"	12.70	50 to 62 (500 to 620)	5/8"	15.88	63 to 77 (630 to 770)	3/4"	19.06	90 to 110 (900 to 1100)	<table border="1" style="width: 100%; border-collapse: collapse;"> <thead> <tr> <th>Nominal diameter</th> <th>Outer diameter (mm)</th> <th>Tightening torque N.m (kgf.cm)</th> </tr> </thead> <tbody> <tr> <td>13/16"-16</td> <td>20.63</td> <td>43-47 (430-470)</td> </tr> <tr> <td>1"-14</td> <td>25.4</td> <td>70-80 (700-800)</td> </tr> <tr> <td>1-1/4"-12</td> <td>31.75</td> <td>120-135 (1200-1350)</td> </tr> <tr> <td>1-3/4"-12</td> <td>44.45</td> <td>135-160 (1350-1600)</td> </tr> <tr> <td>2-1/4"-12</td> <td>57.15</td> <td>165-190 (1650-1900)</td> </tr> </tbody> </table>	Nominal diameter	Outer diameter (mm)	Tightening torque N.m (kgf.cm)	13/16"-16	20.63	43-47 (430-470)	1"-14	25.4	70-80 (700-800)	1-1/4"-12	31.75	120-135 (1200-1350)	1-3/4"-12	44.45	135-160 (1350-1600)	2-1/4"-12	57.15	165-190 (1650-1900)
Nominal diameter	Outer diameter (mm)	Tightening torque N.m (kgf.cm)																																				
1/4"	6.35	14 to 18 (140 to 180)																																				
3/8"	9.52	33 to 42 (330 to 420)																																				
1/2"	12.70	50 to 62 (500 to 620)																																				
5/8"	15.88	63 to 77 (630 to 770)																																				
3/4"	19.06	90 to 110 (900 to 1100)																																				
Nominal diameter	Outer diameter (mm)	Tightening torque N.m (kgf.cm)																																				
13/16"-16	20.63	43-47 (430-470)																																				
1"-14	25.4	70-80 (700-800)																																				
1-1/4"-12	31.75	120-135 (1200-1350)																																				
1-3/4"-12	44.45	135-160 (1350-1600)																																				
2-1/4"-12	57.15	165-190 (1650-1900)																																				
<table border="1" style="width: 100%; border-collapse: collapse;"> <thead> <tr> <th>Nominal Thread size</th> <th>Tightening torque N.m (kgf.cm)</th> </tr> </thead> <tbody> <tr> <td>M24X1P</td> <td>50 (510)</td> </tr> <tr> <td>M18X1P</td> <td>20 (204)</td> </tr> <tr> <td>G1/2"-BSP</td> <td>30 (305)</td> </tr> </tbody> </table>	Nominal Thread size	Tightening torque N.m (kgf.cm)	M24X1P	50 (510)	M18X1P	20 (204)	G1/2"-BSP	30 (305)																														
Nominal Thread size	Tightening torque N.m (kgf.cm)																																					
M24X1P	50 (510)																																					
M18X1P	20 (204)																																					
G1/2"-BSP	30 (305)																																					

<p style="text-align: center;">Tightening Torque of Fusible Plug joint (NPT)</p>	<p style="text-align: center;">Tightening Torque of Mounting bolt of Receiver</p>	<p style="text-align: center;">Scan QR Code for Catalogue</p> <div style="display: flex; justify-content: space-around;">   </div> <p style="text-align: center;">Fusible Plug Snub Adaptors</p> <p style="text-align: center;">For more details, please visit our website www.dryall.net</p>														
<table border="1" style="width: 100%; border-collapse: collapse;"> <thead> <tr> <th>Nominal Thread size</th> <th>Tightening torque N.m (kgf.cm)</th> </tr> </thead> <tbody> <tr> <td>1/4" NPT</td> <td>12 to 24 (122 to 244)</td> </tr> <tr> <td>3/8" NPT</td> <td>24 to 40 (244 to 407)</td> </tr> <tr> <td>1/2" NPT</td> <td>46 to 68 (469 to 693)</td> </tr> </tbody> </table>	Nominal Thread size	Tightening torque N.m (kgf.cm)	1/4" NPT	12 to 24 (122 to 244)	3/8" NPT	24 to 40 (244 to 407)	1/2" NPT	46 to 68 (469 to 693)	<table border="1" style="width: 100%; border-collapse: collapse;"> <thead> <tr> <th>Nominal Thread size</th> <th>Tightening torque N.m (kgf.cm)</th> </tr> </thead> <tbody> <tr> <td>M8x1.5</td> <td>20 (204)</td> </tr> <tr> <td>M10x1.5</td> <td>51 (520)</td> </tr> </tbody> </table>	Nominal Thread size	Tightening torque N.m (kgf.cm)	M8x1.5	20 (204)	M10x1.5	51 (520)	
Nominal Thread size	Tightening torque N.m (kgf.cm)															
1/4" NPT	12 to 24 (122 to 244)															
3/8" NPT	24 to 40 (244 to 407)															
1/2" NPT	46 to 68 (469 to 693)															
Nominal Thread size	Tightening torque N.m (kgf.cm)															
M8x1.5	20 (204)															
M10x1.5	51 (520)															